

LIGHTING BY WALK-IN BOX MANUFACTURER. ELECTRICAL HOOK UP, BULBS, AND WALK-IN BOX OCCUPANCY CONTROL BY GENERAL CONTRACTOR, TYP.

1 LIGHTING PLAN - SECOND FLOOR
E-101.00 3/16"=1'-0"

LIGHTING FIXTURE SCHEDULE:

SYMBOL	TYPE	DESCRIPTION	MANUFACTURER	FIXTURE MODEL NO.	VOLT	NO. FIXTURES	LAMP TYPE
	A	2x4 LED LAY IN	ORACLE LTG	Z4-FPL1-LED-5000L-DIM10-MVOLT-35-85-DIMENSIONS:2'x4' LED FLAT PANEL COLOR:WHITE	120	35	52 WATTS LED
	EM	EMERGENCY LED	EXITRNOIX	EMER BATTERY PACK MODEL:LED-90 COLOR:WHITE	120	21	2.2 WATTS LED
	L-6	6" RECESSED LED	HERMITAGE	LD6IC-AT-DIMTR-120 DIMENSIONS:6" DIAMETER COLOR:WHITE TO BE USE WITH MODULE REL637	120	14	16 WATTS LED
	EX	EXIT LIGHT	EXITRNOIX	REMOTE EMERG HEAD MODEL:LED-U-WH-EL90R COLOR: WHITE	120	8	2.2 WATTS LED
	CL	WALK IN BOX LIGHT FIXTURE	SUPPLIED BY WALK-IN MANUFACTURER INSTALLED BY G.C.	TBD	TBD	8	TBD
	LS-1	TBD	TBD	TBD	TBD	5	TBD
	PL-1	TBD	HINKLEY LIGHTING	SOMERSET 3407KZ COLOR: COPPER	120	5	100 WATTS LED
	PL-2	TBD	HINKLEY LIGHTING	SOMERSET 3407KZ COLOR: TEAL	120	4	100 WATTS LED
	PL-3	TBD	TBD	TBD	TBD	4	TBD
	WS-1	TBD	TBD	TBD	TBD	5	TBD
	WS-2	TBD	TBD	TBD	TBD	6	TBD
	L-2	TBD	WESTGATE	SCX-8FT-80W-50K-D	120	9	80 WATTS LED
	L-3	TBD	WESTGATE	SCX-6FT	120	2	60 WATTS LED

REFER TO REFLECTED CEILING PLAN IN ARCHITECTURAL DRAWINGS FOR MORE INFORMATION ON COLORS AND TRIMS REQUIRED

ELECTRICAL LIGHTING PLAN KEYED WORK NOTES:

- A PROVIDE CEILING MOUNTED RECEPTACLE FOR SHOW WINDOW AS REQUIRED BY CODE. VERIFY WITH LOCAL ENERGY AGENCY. VERIFY EXACT LOCATION WITH ARCHITECT.
- B EC SHALL COORDINATE EXACT LOCATION OF THE LIGHTING CONTROL PANEL "LCP" WITH ARCHITECT/OWNER.
- C JUNCTION BOX ON HOOD FOR RE-WIRED HOOD LIGHTS.
- D CONNECT ALL EMERGENCY EGRESS AND NIGHT LIGHTING FIXTURES TO THE NEAREST LIGHTING BRANCH CIRCUIT AHEAD OF ALL SWITCHING AND CONTROLS PER STATE AND LOCAL CODES.
- E LIGHTING BY W.I.B MANUFACTURER. EC TO PROVIDE RACEWAYS, WIRING AND LAMPS FOR ALL LIGHT FIXTURES FURNISHED WITH THE FREEZER/COOLER STORAGE UNIT. COORDINATE THE INSTALLATION OF SWITCHES AND PLATES WITH THE EQUIPMENT SUPPLIER.
- F EXHAUST FANS SHALL BE CIRCUITED AND CONTROLLED ALONG WITH THE LIGHT FIXTURES IN THE SAME ROOM.
- G CONNECTIONS FOR SECURITY CAMERA. VERIFY EXACT LOCATIONS AND TYPE CONNECTIONS FOR INDOOR AND OUTDOOR CAMERAS WITH OWNER. COORDINATE CAMERA INSTALLATIONS BENEATH AWNINGS SO AS TO AVOID OBSTRUCTED VIEWS. ALSO E.C. TO COORDINATE THE LOCATION OF CAMERA WITH ARCHITECT BEFORE COMMENCEMENT OF WORK.
- H FIXTURE WHICH ARE NOT CONTROLLING BY OCCUPANCY SENSOR IS CONTROLLING WITH TIME CLOCK/LCP.

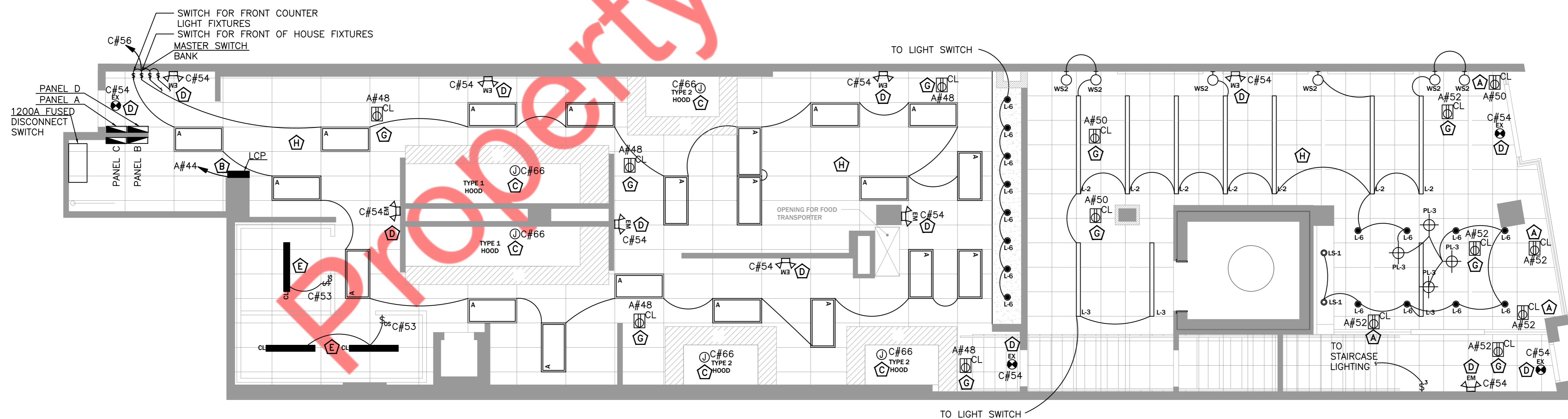

2 LIGHTING PLAN - FIRST FLOOR
E-101.00 3/16"=1'-0"

- ELECTRICAL POWER PLAN GENERAL NOTES:**
- VERIFY MOUNTING HEIGHTS OF ALL RECEPTACLES WITH EQUIPMENT SUPPLIED PRIOR TO INSTALLATION.
 - E.C. TO PROVIDE CORD & PLUG CONNECTIONS FOR EQUIPMENT AS REQUIRED.
 - ALL 120V, 20A OUTLETS IN THE FOOD PREP AREA SHALL BE GROUND FAULT INTERRUPT TYPE.
 - ALL CIRCUITS FOR P.O.S. (POINT OF SALE) EQUIPMENT SHALL BE CONNECTED TO THE SAME PHASE OF POWER IN THE PANEL. ALL BRANCH CIRCUIT BREAKERS SUPPLYING P.O.S. EQUIPMENT SHALL HAVE LOCKING HANDLES DEVICES.
 - EACH RECEPTACLE TYPE (LOCKING OR STRAIGHT BLADE) SHALL MATCH THAT OF THE EQUIPMENT FURNISHED.
 - E.C. TO VERIFY ALL EQUIPMENTS ROUGH IN REQUIREMENT WITH MANUFACTURER.
 - REFER E-202.00 FOR KITCHEN EQUIPMENT SCHEDULE.

- ELECTRICAL POWER PLAN KEYED WORK NOTES:**
- EC TO PROVIDE 2P30A NEMA 3R FUSED DISCONNECT SWITCH AND L.T. FLEX CONNECTION TO ROOF MOUNTED ICE MAKER CONDENSER UNIT IF AVAILABLE, FUSE SIZE PER MANUFACTURER'S NAME PLATE DATA.
 - EC SHALL PROVIDE BACK BOX AND CONDUIT WITH PULL STRING FOR MECHANICAL UNIT THERMOSTAT. CONFIRM FINAL LOCATION WITH MECHANICAL DRAWINGS PRIOR TO ROUGH-IN.
 - PROVIDE TWO (2) CAT6 HOMERUN TO DESK AND ONE (1) QUAD 20 AMP RECEPTACLE AT 18" A.F.F. AT DESK. COORDINATE EXACT LOCATION WITH OWNER PRIOR TO ROUGH-IN.
 - PROVIDE TWO (2) CAT 6 HOMERUN TO EACH POS AND TWO (2) QUAD 20 AMPS RECEPTACLE AT 15" A.F.F. AT COUNTER FOR POS COORDINATE WITH OWNER PRIOR TO ROUGH-IN.
 - JUNCTION BOX FOR HAND DRYER. COORDINATE MOUNTING HEIGHT WITH ARCHITECT.
 - POWER FOR HEAT TRACE AT GREASE RECOVERY UNIT. EC TO FIELD VERIFY EXACT LOCATION.
 - ELECTRICAL CONTRACTOR SHALL COORDINATE DISCONNECT AND FUSE REQUIREMENT FOR MECHANICAL UNIT WITH MECHANICAL CONTRACTOR AND EQUIPMENT MANUFACTURER PRIOR TO ROUGH-IN. AND PROVIDE AS REQUIRED. COORDINATE LOCATION OF DISCONNECT WITH MANUFACTURER AND MECHANICAL CONTRACTOR PRIOR TO ROUGH-IN. LOCATE AS REQUIRED TO MAINTAIN NEC CLEARANCES.
 - ELECTRICAL CONTRACTOR TO COORDINATE EXACT POWER REQUIREMENT WITH WALK IN BOX MANUFACTURER AND MAKE POWER PROVISION ACCORDINGLY.
 - EC TO FIELD VERIFY LOCATION OF CONDENSING UNIT AND PROVIDE POWER CONNECTION WITH NECESSARY ELECTRICAL FIXTURES/ DISCONNECTS AS PER MANUFACTURER REQUIREMENTS.
 - EC TO PROVIDE FINAL POWER CONNECTION FOR HEAT TAPE AND DOOR HEATER AS PER MANUFACTURER REQUIREMENTS.
 - EC SHALL INSTALL AND WIRE RELAY CONTROL PANEL PACKAGE FOR HOOD EXHAUST FANS KEF-1 AND KEF-2. PROVIDE POWER AND INTERLOCK CONTROL WIRING FOR CONTROL PANEL AND HOOD FIRE SUPPRESSION SYSTEM. SEE FAN CONTROL INTERLOCK WIRING DIAGRAM. SHEET H-100, H-101. MOUNT STARTERS AND CONTROL ON WALL. EC TO PROVIDE SELECTOR SWITCH AND PILOT LIGHT IN NEMA 4X STAINLESS STEEL ENCLOSURE MOUNTED ON THE FACE OF THE HOOD. PROVIDED BY HOOD MANUFACTURER.
 - REFER TO EQUIPMENT SPECIFICATIONS FOR DATA AND POWER REQUIREMENTS AND LOCATIONS FOR ALL MENU BOARDS. EC TO VERIFY THE LOCATION OF MENUBOARD WITH ARCHITECT.
 - EC TO FIELD VERIFY THE LOCATION OF THE HOOD EXHAUST FANS KEF-1 & KEF-2 WHICH SHALL BE LOCATED ON THE ROOF. EC SHALL REFER TO MECHANICAL DRAWINGS FOR DETAILS. E.C. SHALL PROVIDE APPROPRIATE DISCONNECT SWITCH FOR THE EQUIPMENT CONNECTION AND FEED THEM VIA PANEL "D". EC TO COORDINATE WITH OWNER/ EQUIPMENT MANUFACTURER FOR EXACT LOCATION AND CONNECTION OF THE EQUIPMENT.
 - PROVIDE CEILING OUTLET RECEPTACLES SUPPORTED FROM BUILDING STRUCTURE FOR VIDEO MONITOR/ PRINTER & OR HEADSET. EC SHALL VERIFY EXACT REQUIREMENTS AND LOCATION WITH OWNER/ARCHITECT.
 - EC TO COORDINATE FINAL LOCATION OF CONTROLLER FOR DUMBWATER WITH ARCHITECT.
 - EC TO VERIFY EXISTING LOCATION OF CONDUITS FOR TELECOM, ELECTRICAL & FIRE ALARM AT SITE. SINCE IT COMES IN WALK IN COOLER ROOM E.C. TO COORDINATE WITH ARCHITECT FOR NEW ROUTING OF CONDUITS FROM CELLAR BEFORE COMMENCEMENT OF WORK AND BASE BID ACCORDINGLY.
 - EC TO COORDINATE FINAL LOCATION WITH LIFT MANUFACTURER & ARCHITECT.
 - EC TO COORDINATE WITH ARCHITECT FOR TYPE OF FRYER. FOR ELECTRICAL TYPE FRYER EC TO PROVIDE 3 PHASE CIRCUIT + 1 PHASE CIRCUIT FROM PANEL AS SHOWN. BUT FOR GAS FRYER EC TO PROVIDE ONLY 1 PHASE SUPPLY FROM PANEL. EC TO COORDINATE WITH FRYER MANUFACTURER FOR ROUGH IN DETAILS BEFORE COMMENCEMENT OF WORK.

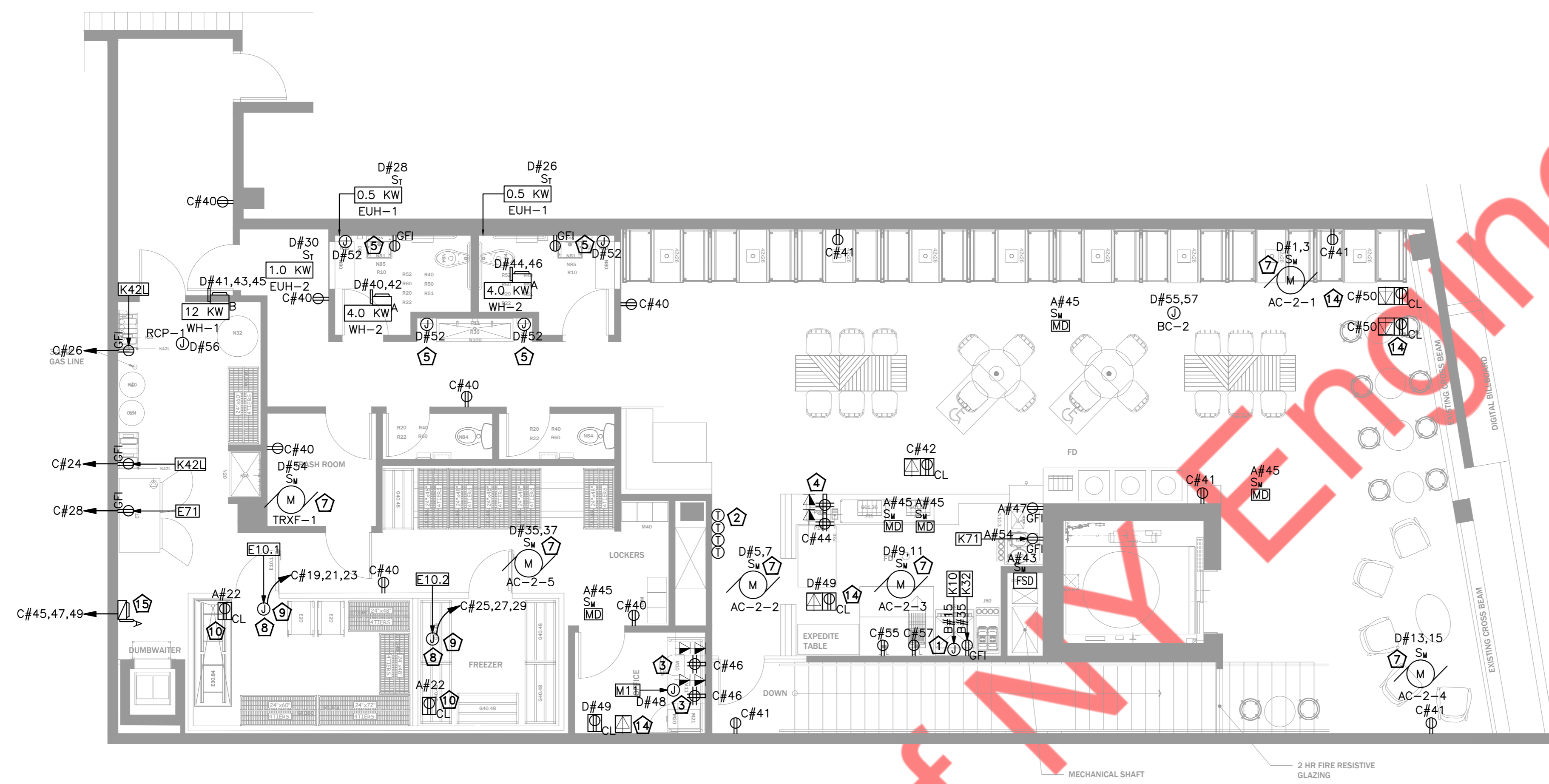

1 ELECTRICAL POWER PLAN - SECOND FLOOR
E-201.00 3/16"=1'-0"

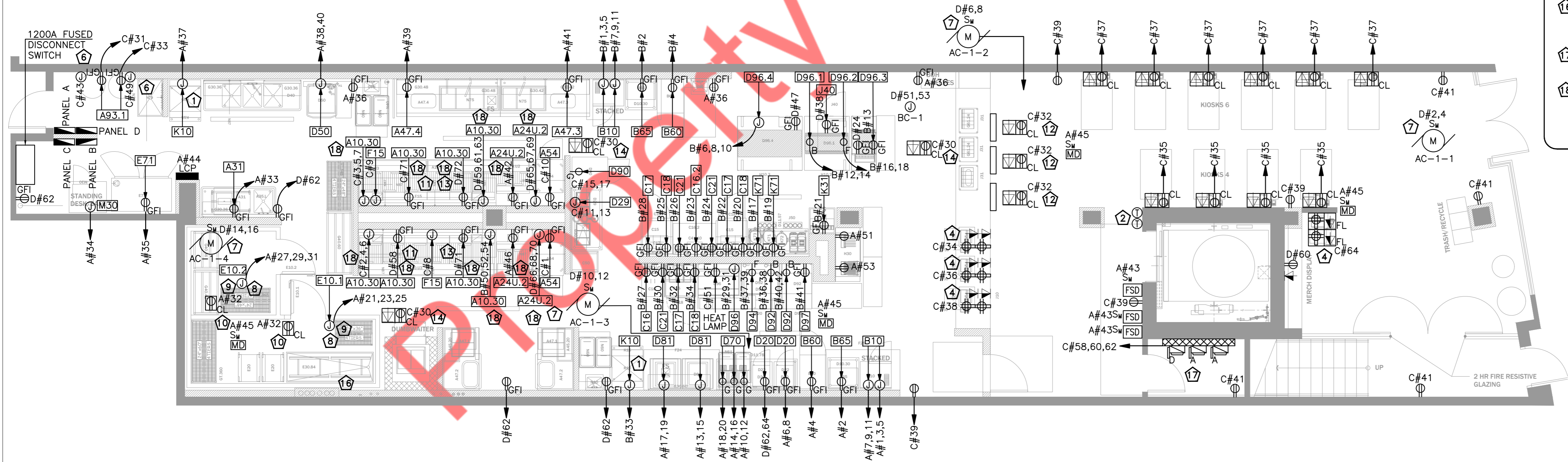

2 ELECTRICAL POWER PLAN - FIRST FLOOR
E-201.00 3/16"=1'-0"

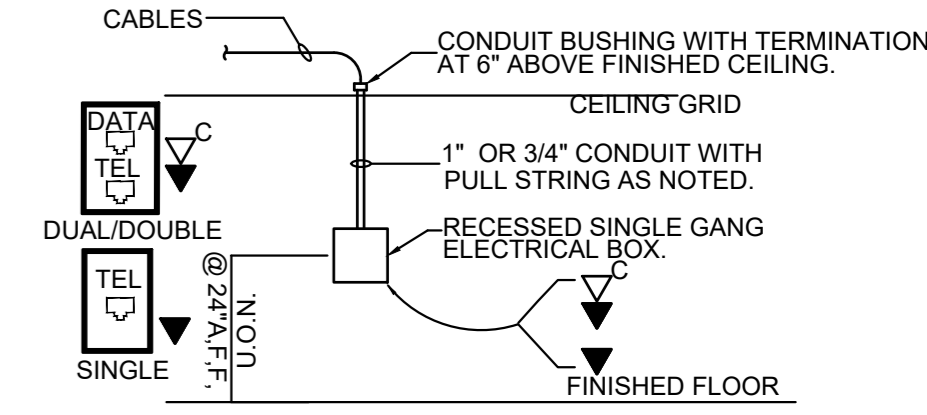

3 TYP COMM. STUB UP DETAIL
E-201.00 NTS

- NOTES:
1. MONITOR BRACKETS TO BE SUPPLIED AND INSTALLED BY P.O.S. VENDOR.
 2. G.C. TO SUPPLY 2x4 BLOCKING AND TO SECURE BLOCKING AT LOCATION PER P.O.S. VENDOR DIRECTION. VERIFY W/P.O.S. VENDOR BEFORE INSTALLATION

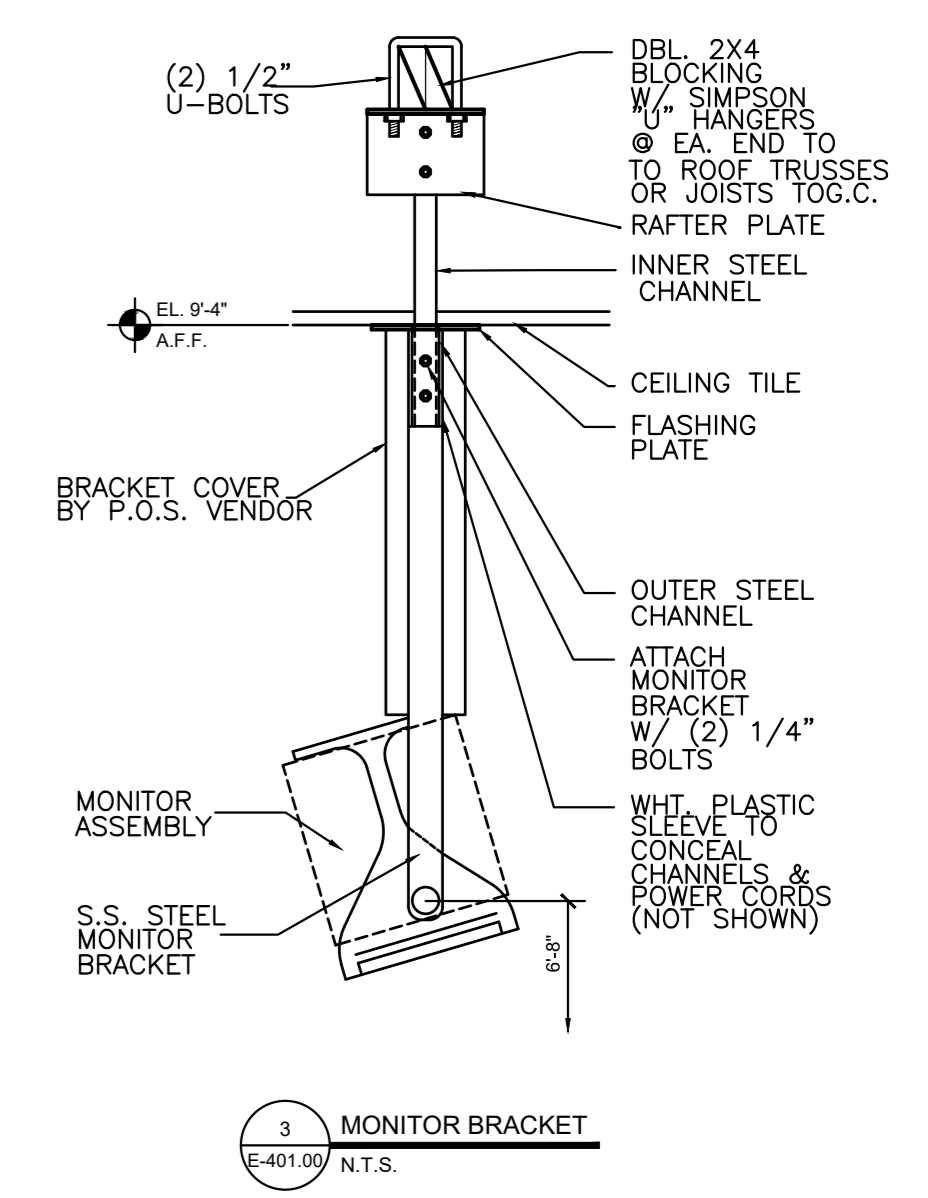

3 MONITOR BRACKET
E-401.00 N.T.S.

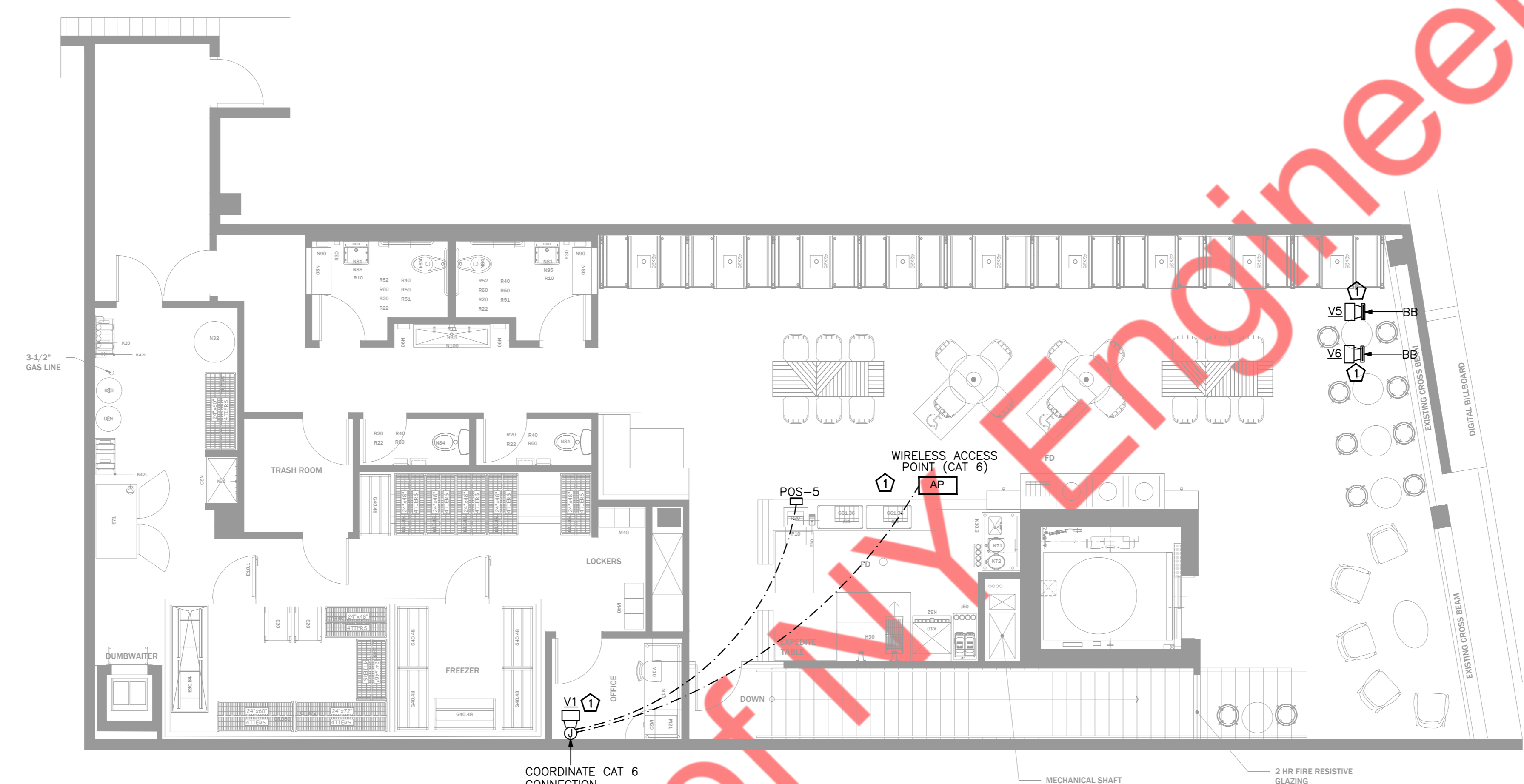

1 POS WIRING DIAGRAM - SECOND FLOOR
E-401.00 3/16"=1'-0"

REFERENCE ONLY
COORDINATE WITH OWNERS P.O.S. SUPPLIER

- REGISTER CONNECTIONS
1. CABLES SHALL BE CAT6.
 2. BUMP BARS SHALL BE MOUNTED TO DELIVERY SYSTEM AT AREAS MARKED "BB".
 3. BUMP BAR CABLES SHALL BE RUN THROUGH DELIVERY SYSTEM FROM MOUNT UP THROUGH WALLS TO ABOVE THE CEILING AND BACK TO THE MANAGER STATION.
 4. CRT MONITORS SHALL BE MOUNTED ON CEILING BRACKETS PROVIDED BY REGISTER SYSTEM.
 5. WHERE CABLING IS INSTALLED IN WALLS, IT SHALL BE ROUTED IN A 1" CONDUIT THROUGH WALL TO ABOVE ACCESSIBLE CEILING.

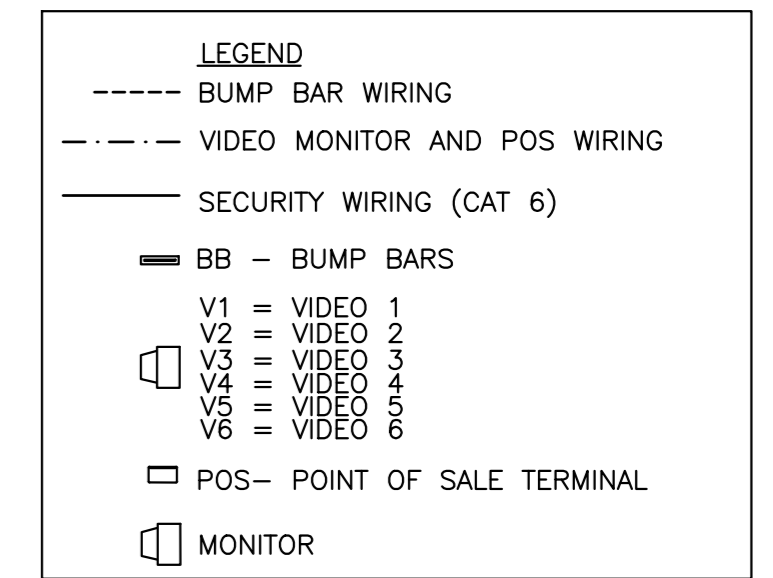

ELECTRICAL KEYED WORK NOTES:

CONTRACTOR TO COORDINATE FOR FINAL LOCATIONS & QUANTITY OF VIDEO MONITOR WITH ARCHITECT BEFORE COMMENCEMENT OF WORK.

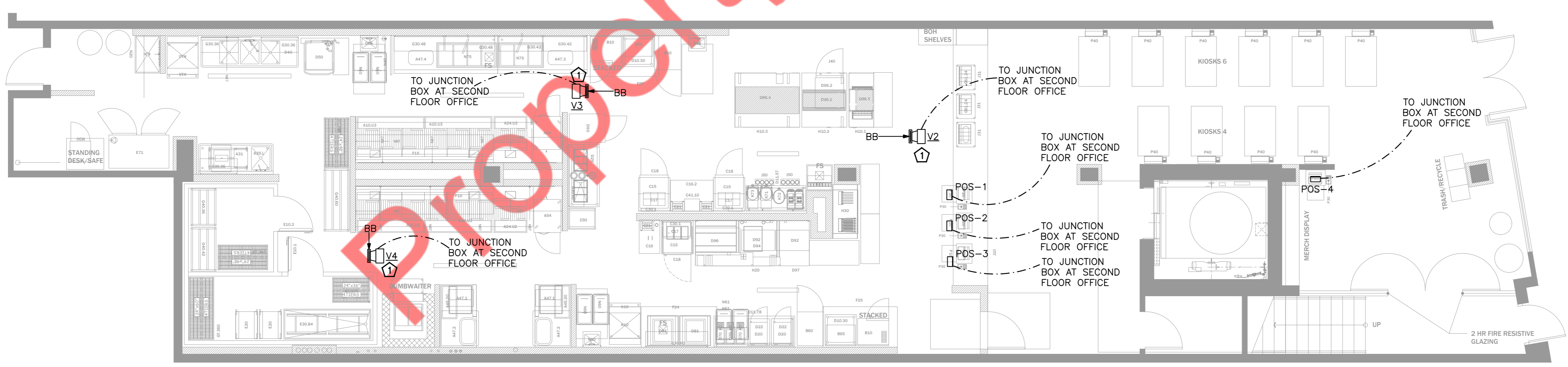

2 POS WIRING DIAGRAM - FIRST FLOOR
E-401.00 3/16"=1'-0"

POPEYES INSTALLATION NOTES

NOTE: PROGRAMMING SEQUENCE SET-UP AT THE NCCC

INDOOR CAMERAS

INDOOR CEILING MOUNT IN TINTED DOME

FASTEN SCREW IN CEILING FOR DOMES SO NOT EASILY DROPPED OUT OF TILE

- B-1 & B-2 : VIEW OF ENTRNCE
- B-3 TO B-6 : VIEW SALES COUNTER AND SALES AREA
- B-7 TO B-9 : VIEW OF KITCHEN & REAR ENTRANCE
- B-11 : VIEW OF OFFICE
- B-12 TO B-14 : VIEW OF DINING AREA
- B-15,B-15A : VIEW OF RESTROOM PASSAGE

OFFICE AREA

BAC- BURGLAR ALARM CONTROL-VISTA 20SEUL

D-VCR
E-VCR :
F-MONITOR :

QUICK REFERENCE SHEETS

ALARM INSTRUCTION SHEET TO BE MOUNTED ON WALL IN EMPLOYEE ONLY AREA CLOSEST TO KEYPAD OR IN OFFICE AREA PER CUSTOMER INSTRUCTION

FOR LOCATIONS WITH 6 OR MORE CAMERAS: ADD MULTIPLEXER

LTC 2641/60-PLACE ON SECURITY LOCK FOR NO TAMPER

FOR LOCATIONS WITH 4 CAMERAS OR LESS:

ADD VIDQUAD 4 CHANNEL LTC 2272/60

HUB: HOLD UP BUTTON 441494 SERIES LATCHING HUB

MANAGER AREA-36" AFF OUT OF SITE FROM FRONT COUNTER

DRIVE-THRU WINDOW-18" AFF & OUT OF SITE FROM OUTSIDE

FRYER/PREP AREA

SL: STROBE LIGHT - AS SL-401B-BLUE STROBE MOUNT BEHIND MENU BOARD, IT WILL FLASH CONTINUOUSLY WHILE BACK DOOR IS OPEN

S: SOUNDER-AS-PAL328N-LOW TONE SOUNDER MOUNT WITH STROBE BEHIND MENU BOARD, IT WILL SOUND WHEN BACK DOOR IS OPENED, MANAGER WILL SILENCE ST SOUNDER AT KEYPAD AFTER 1 TONE

MD: MOTION DETECTOR-AP 669 PIR-360 MOTION MOUNT IN STOVE AREA TO GET AREA FROM DRIVE-UP WINDOW AND GENERAL REAR AREA

LOBBY/PERIMETER AREA/BACK OF HOUSE

KP: KEY PAD-MOUNT 40" AFF

GB: FG 1025 GLASS BREAK-LOBBY GLASS ONE EACH SIDE OF BUILDING SEE DRAWING FOR DEVICE PLACEMENT

C: B4039 CONTACT-ALL EXTERIOR DOORS

BACK DOOR CONTACT TO ACT AS ALARM POINT FOR BACK DOOR ALARM-24 HOUR LOCATION POINT-SOUNDER & BLUE STROBE TO ACTIVATE WHEN BACK DOOR IS OPEN

HUB: 3050CT SERIES LATCHING HUB IN COOLER/FREEZER-MOUNT 18" AFF ON HINGE SIDE OF DOOR, STUB UP CONDUIT TO PROTECT WIRING FROM CONDENSATION/DAMAGE NO DRIP LOOP AT HUB

POC : POINT OF CONNECTION TO NKL SAFE-PIGTAIL PROVIDED BY NKL SAFE

POPEYES ADD ON MODIFICATION NAMES AND PHONE NUMBERS

1. INSTALLER PLEASE CONTACT POPEYES CONSTRUCTION MANAGER FOR ANY ADD-ONS OR MODIFICATIONS TO YOUR JOB. THEY WILL CONTACT THE NATIONAL ACCOUNT MANAGER FOR APPROVALS/PAPERWORK.

POPEYES ADD ON MODIFICATION NAMES AND PHONE NUMBERS

1. INSTALLER PLEASE CONTACT POPEYES CONSTRUCTION MANAGER FOR ANY ADD-ONS OR MODIFICATIONS TO YOUR JOB. THEY WILL CONTACT THE NATIONAL ACCOUNT MANAGER FOR APPROVALS/PAPERWORK.

POPEYES MATERIAL LIST

CAMERAS

INDOOR CEILING MOUNT IN TINTED DOME
NOTE: FASTEN SCREW IN CEILING FOR DOMES SO NOT EASILY DROPPED OUT OF TILE LTC 0430/20-38 SERIES CAMERA W/ 3.5MM-BMM VARIFOCAL AUTOIRIS LENS TC 9345MT7 INDOOR TINTED DOME BNC CONNECTORS FOR PLENUM CABLE

OFFICE AREA

BAC-BURGLAR ALARM CONTROL: VISTA 20SEUL
D-VCR LOCK BOX : TC3922 SERIES
E-VCR: LTC 3924 SERIES PLACE ON SECURITY LOCK FOR NO TAMPER

F-MONITOR: LTC 2813/60 SERIES
ALTV248: 8 POSITION POWER SUPPLY
QUICK REFERENCE SHEETS
ALARM INSTRUCTION SHEET TO BE MOUNTED ON WALL IN EMPLOYEE ONLY AREA CLOSEST TO KEYPAD OR IN OFFICE AREA PER CUSTOMER INSTRUCTION
VCR INSTRUCTION SHEETS (2) 1-REVIEW & 1-RECORD-TO BE MOUNTED ON WALL CLOSEST TO VCR

FOR LOCATIONS WITH 6 OR MORE CAMERAS : ADD MULTIPLEXER LTC 2641/60-PLACE ON SECURITY LOCK FOR NO TAMPER

FOR LOCATIONS WITH 4 CAMERAS OR LESS : ADD VIDQUAD 4 CHANNEL LTC 2272/60

2-HUB: HOLD UP BUTTON 441494 SERIES LATCHING HUB

STOVE/PREP AREA

SL: STROBE LIGHT-AS SL-401B-BLUE STROBE MOUNT BEHIND MENU BOARD, IT WILL FLASH CONTINUOUSLY WHILE BACK DOOR IS OPEN

S: SOUNDER-AS-PAL328N-LOW TONE SOUNDER MOUNT WITH STROBE BEHIND MENU BOARD, IT WILL SOUND WHEN BACK DOOR IS OPENED, MANAGER WILL SILENCE ST SOUNDER AT KEYPAD AFTER 1ST TONE

MD: MOTION DETECTOR-AP 669 PIR-360 MOTION MOUNT IN STOVE AREA TO GET AREA FROM DRIVE-UP WINDOW AND GENERAL REAR AREA

LOBBY/PERIMETER AREA/BACK OF HOUSE

KP: KEYPAD-MOUNT 40" AFF WALL ENTERING KITCHEN AREA FROM LOBBY

2-GB: FG 1025 GLASS BREAK-LOBBY GLASS ONE EACH SIDE OF BUILDING SEE DRAWING FOR DEVICE PLACEMENT

3 OR 4-C: B4039 CONTACT-ALL EXTERIOR DOORS BACK DOOR CONTACT TO ACT AS ALARM POINT FOR BACK DOOR ALARM-24 HOUR LOCAL POINT-SOUNDER & BLUE STROBE TO ACTIVATE WHEN BACK DOOR IS OPEN

1 OR 2-HUB: 3050CT SERIES LATCHING HUB IN COOLER/FREEZER-MOUNT 18" AFF ON HINGE SIDE OF DOOR SUB UP IN CONDUIT

1-POC: POINT OF CONNECTION TO NKL SAFE-PIGTAIL PROVIDED BY NKL SAFE

RELAYS FOR BACK DOOR/POC/ZONE EXPANSION
TELCO JACK
WATTS LINE

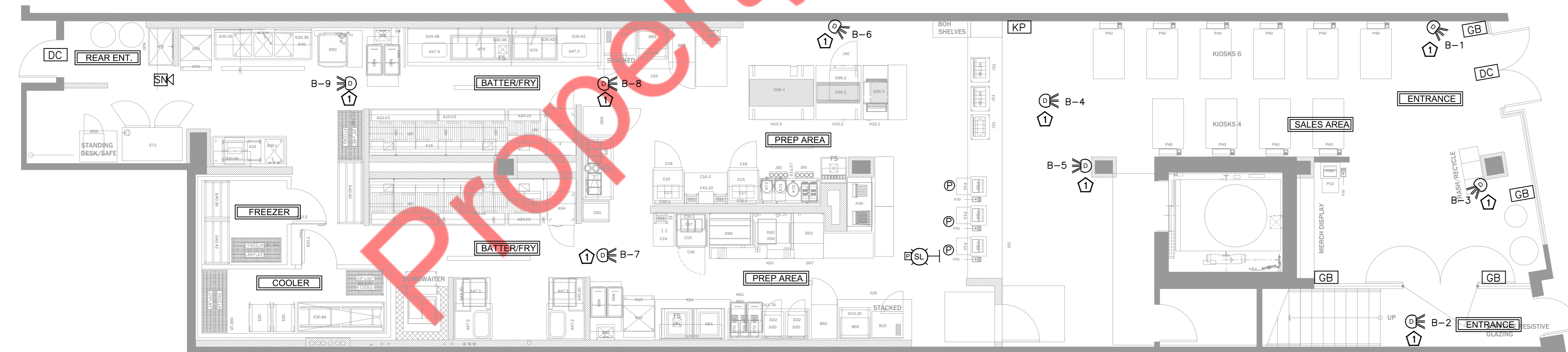

2 SECURITY PLAN - FIRST FLOOR
E-501.00 3/16"=1'-0"

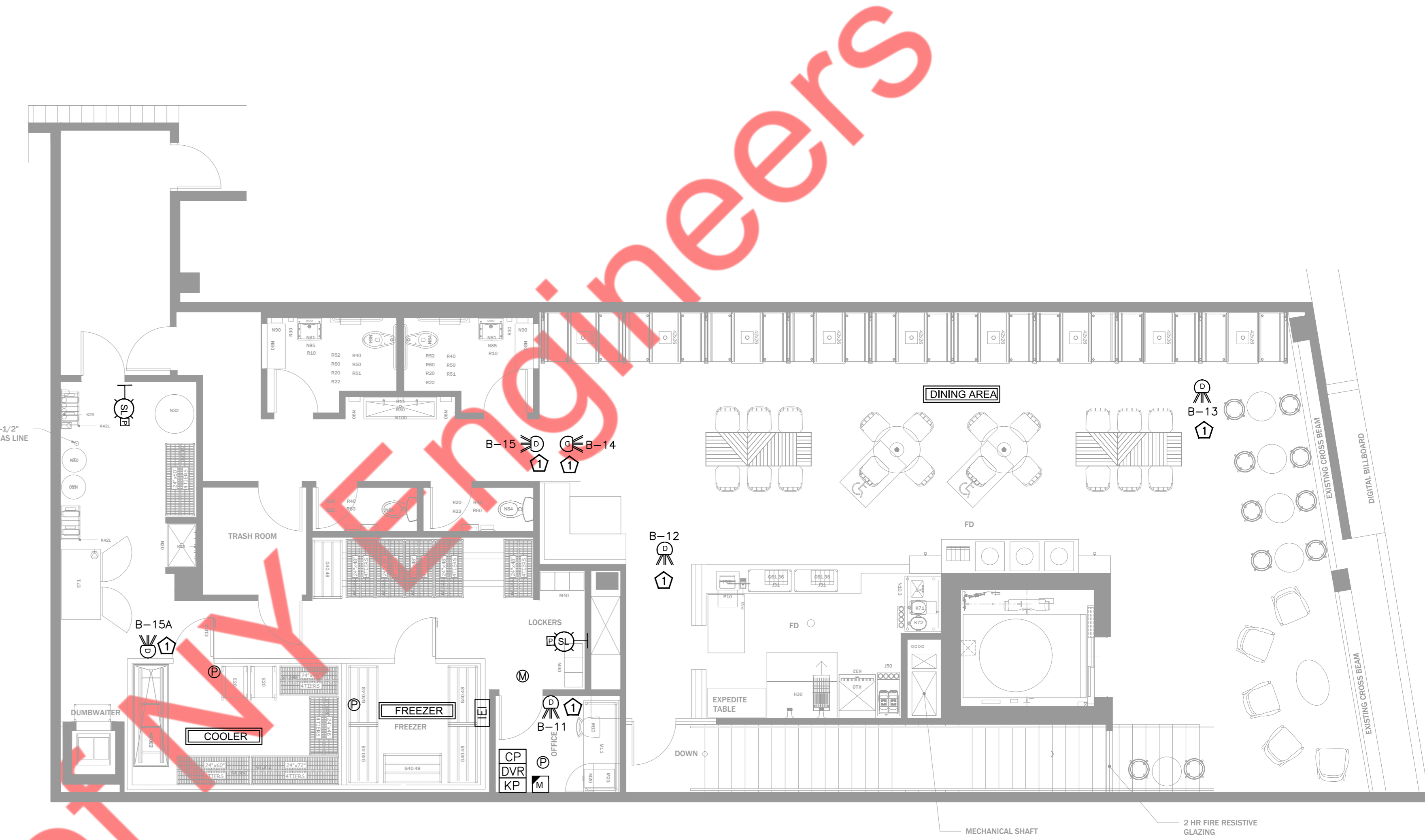

1 SECURITY PLAN - SECOND FLOOR
E-501.00 3/16"=1'-0"

ELECTRICAL SECURITY PLAN GENERAL NOTES:

- A. SECURITY PLAN IS FOR REFERENCE ONLY. G.C. TO COORDINATE WITH OWNER AND OWNER'S SECURITY VENDOR PRIOR TO CONSTRUCTION FOR EXACT LOCATIONS AND SPECIFICATIONS OF LV DEVICES.
- B. ELECTRICAL SUPPLY ALL 120 VAC FOR CAMERA SYSTEM AND BURGLAR ALARM SYSTEM.
- C. SUPPLY 120VAC FOR ALL CCTV HEAD END EQUIPMENT.

LEGEND	
	DOMES
	GLASS BREAK DETECTOR
	CARD READER
	DOOR CONTACT
	KEYPAD
	MOTION DETECTOR
	HOLD UP PANIC BUTTON
	SIREN
	DIGITAL VIDEO RECORDER
	CONTROL PANEL
	IEI KEYPAD
	STROBE LIGHT
	14" MONITOR

ELECTRICAL KEYED WORK NOTES:

CONTRACTOR TO COORDINATE FOR FINAL LOCATIONS & QUANTITY OF DOME WITH ARCHITECT BEFORE COMMENCEMENT OF WORK.